

Irrigation and Drainage Engineering

(Soil Water Regime Management)

(ENV-549, A.Y. 2025-26)

4ETCS, Master option

Prof. Paolo Perona

Platform of Hydraulic Constructions



Lecture 9-2. Drainage:
causes of humidity excess
and remedies

1. Fundamentals
2. Sizing subsurface drainage networks
 - Definition of design parameters
 - Design approaches
 - Calculation of drain spacing and flow rates to be evacuated
 - 1) Permanent regime
 - structures resting on an impermeable layer
 - structures not underlain by an impermeable layer
 - 2) Non-stationary regime
 - structures resting on an impermeable layer
 - structures not underlain by an impermeable layer
 - Geometric characteristics of underground pipe drainage systems
 - How to design a network
3. Materials used for drains
 - Drains
 - Risk of clogged drains
4. Construction and maintenance of drainage networks
5. Tampons Zones

Drainage of soils

Remediation encompasses various techniques for removing excess water from the soil, allowing it to be cultivated and producing sufficient, high-quality produce

Remediation can have 3 objectives:

- remove excess water from the soil
- create new farmland (draining of wetlands)
- prevent salinisation of the soil by capillary rise



Causes of excessive soil humidity

There are three essential causes:

1. External and/or parasitic water input

- ✓ inputs from outside the area
- ✓ inflow from a watercourse
- ✓ parasitic internal inputs ("wetlands")

2. Prolonged presence of a shallow water table

3. Temporary stagnation of rainwater

- ✓ lack of infiltrability
- ✓ lack of internal drainage

1. External and/or parasitic water inputs

- Inflows of water from outside the area to be remediated

Remedy: belt collector (ditch or drain placed at the bottom of a very permeable trench)

- Inflow of water from a watercourse

- ✓ excessive groundwater recharge

Remedy: counter-channel

- ✓ occasional overflow

Remedy: flood control structures.*

- Localised parasitic internal inputs ("wetlands")

- ✓ in depressions or at breaks in the slope

Remedy: catchments or local adaptation of retail drainage

- ✓ Emerging aquifer

*Remedy: drainage trench, afforestation***

- ✓ more or less diffuse resurgences of deep water

Remedy: installation of a permeable material over the entire resurgence area and a drainage trench.

*correction, diking, retention systems; surface development

** to be coordinated with other land uses

Causes of "wet spots" formation

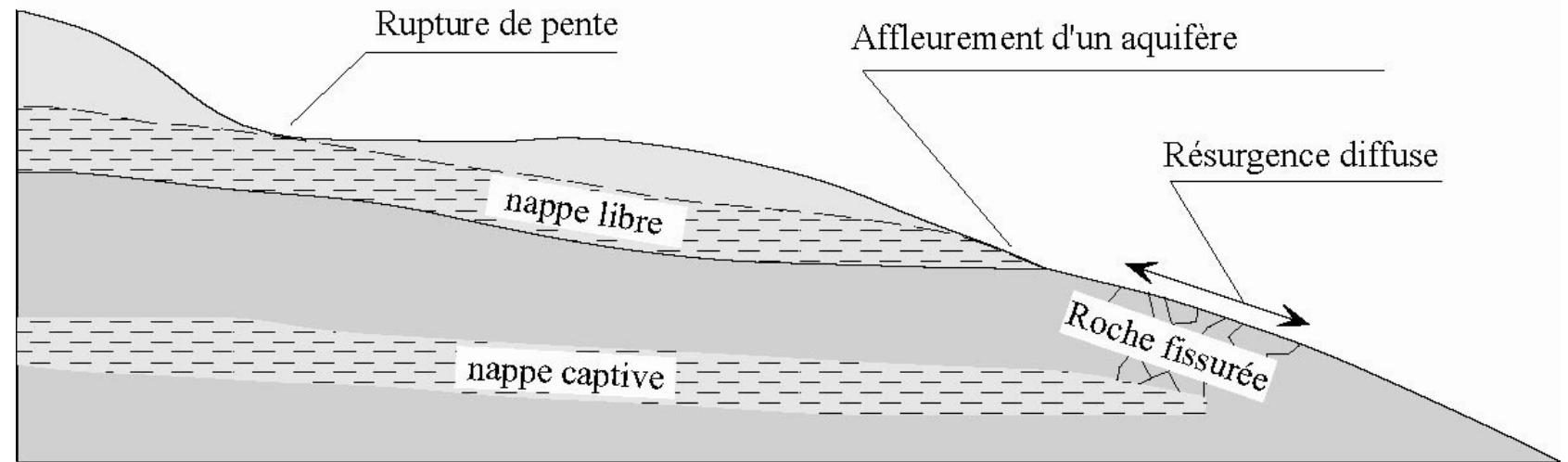

Examples of "wetland" remediation

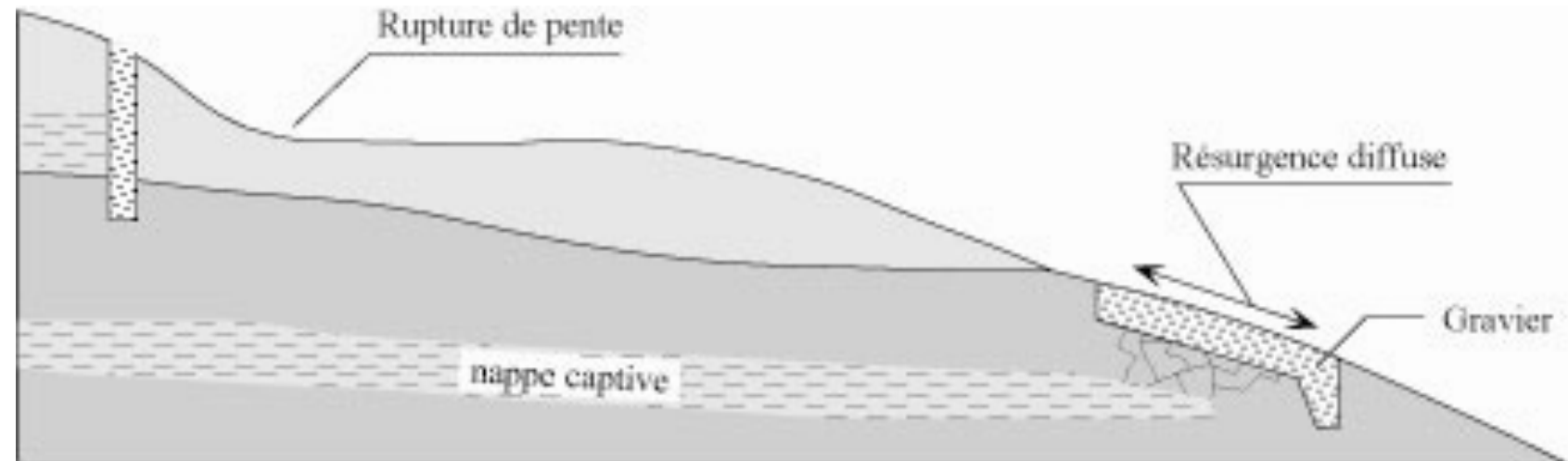

2. Prolonged presence of a shallow water table

- drainage with buried pipes
- if necessary, drainage by ditches
- in some cases, well drainage*
- in the presence of significant lateral inflow: prior interception

* Drainage by local afforestation bases on the same principle, but the efficiency such a solution is to be tested against additional scenarios (e.g., land use, prolonged droughts, long term planning, etc)

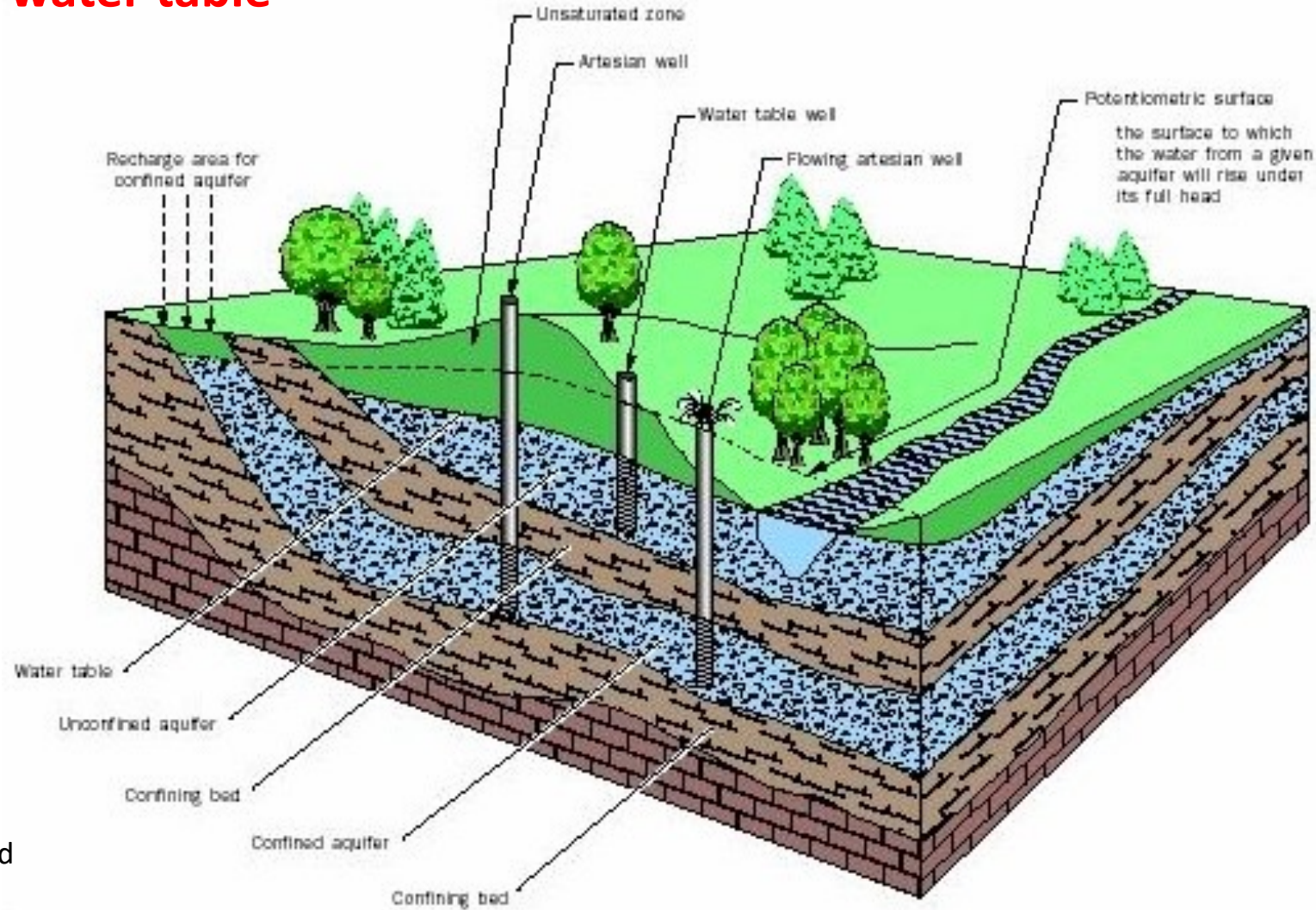

3. Temporary stagnation of rainwater

- **Infiltration deficit :**

due to the presence of a poorly permeable layer on the surface (beaten earth, surface compaction, etc.) which prevents infiltration

→ on flat ground, rainwater stagnates on the surface



Battering crusts

Remedy :

- ✓ if the underneath soil layers have good hydraulic conductivity: improving the structure of the surface layer
- ✓ if not: surface drainage



Temporary stagnation of rainwater

- **Internal drainage defect :**

Deep infiltration prevented by the low hydraulic conductivity of the soil or by the presence of a layer of low permeability at shallow depth (e.g. a plough footing) which blocks infiltration and causes a perched water table to form.



Subsoiling

Remedy :

- ✓ where there is a ploughing surface: deep subsoiling
- ✓ soils with low permeability or shallow perched water table: surface drainage and/or underground drainage; if necessary, associated techniques

Main drainage methods

A. Surface drainage

B. Subsurface drainage

- by open ditches
- by buried drains
 - *classical*
 - *associated techniques*
 - ✓ mole drainage
 - ✓ drainage by drainage galleries

C. Other techniques for lowering the water

table (marginal)

- well drainage
- biodrainage



A. Surface drainage

Used in flat, very gently sloping or irregularly surfaced areas where there is a lack of infiltrability or internal drainage.

Aim : reduce the risk of prolonged submergence of the soil without causing erosion

→ Landform

- **Flattening:** eliminating irregularities in the ground (local depressions, obstacles, etc.), without modifying the overall topography.
- **Levelling:** heavy work on the ground to give it sufficient regularity and slope



Flattening



Levelling

→ Creation (or improvement) of a stormwater collection and drainage network

Surface drainage

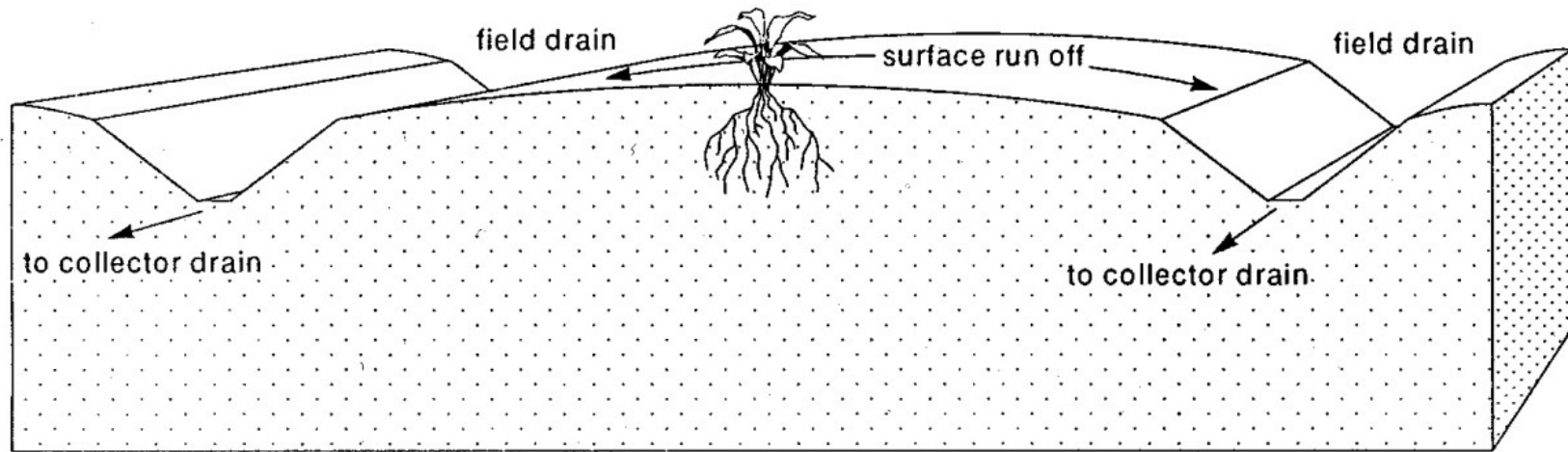

Levelling and flattening works

B. Subsurface drainage

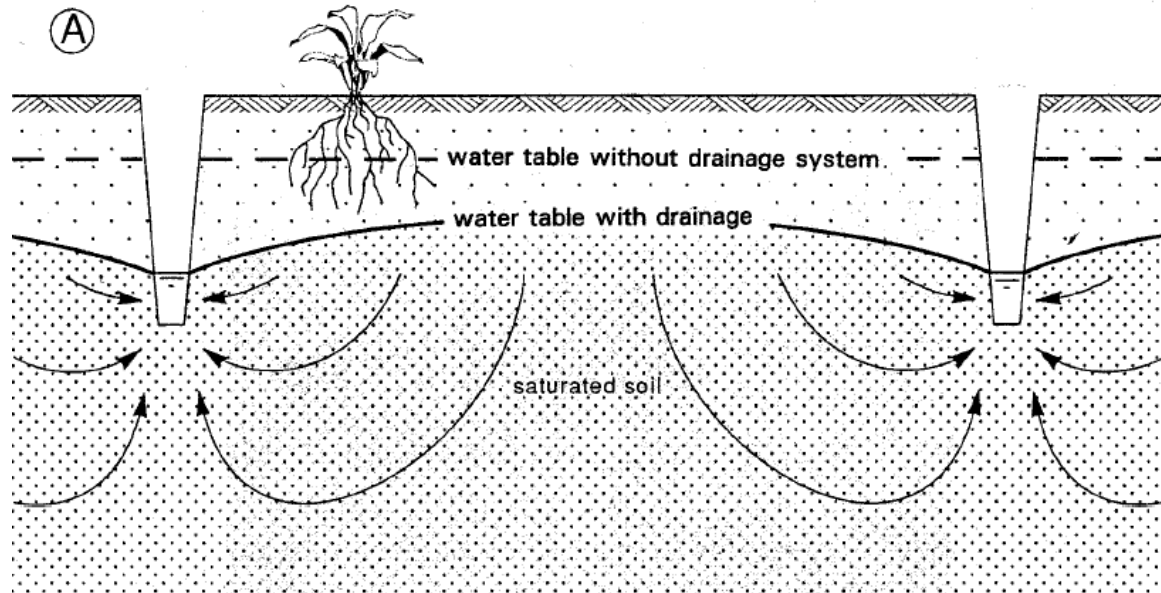

By open ditches

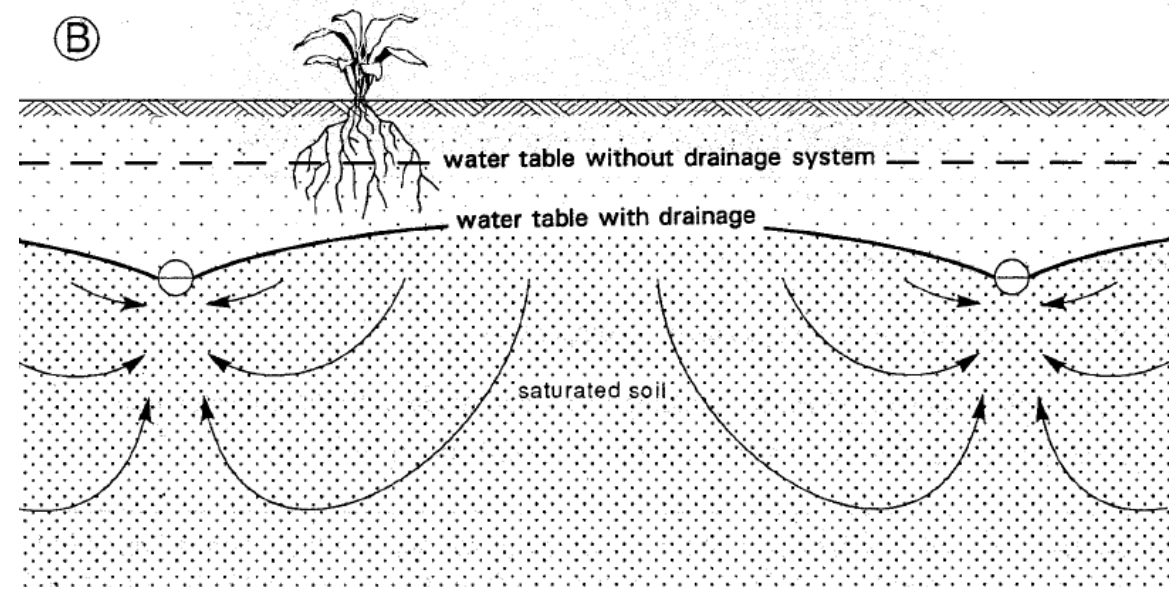

By buried drains

Drainage by open ditches

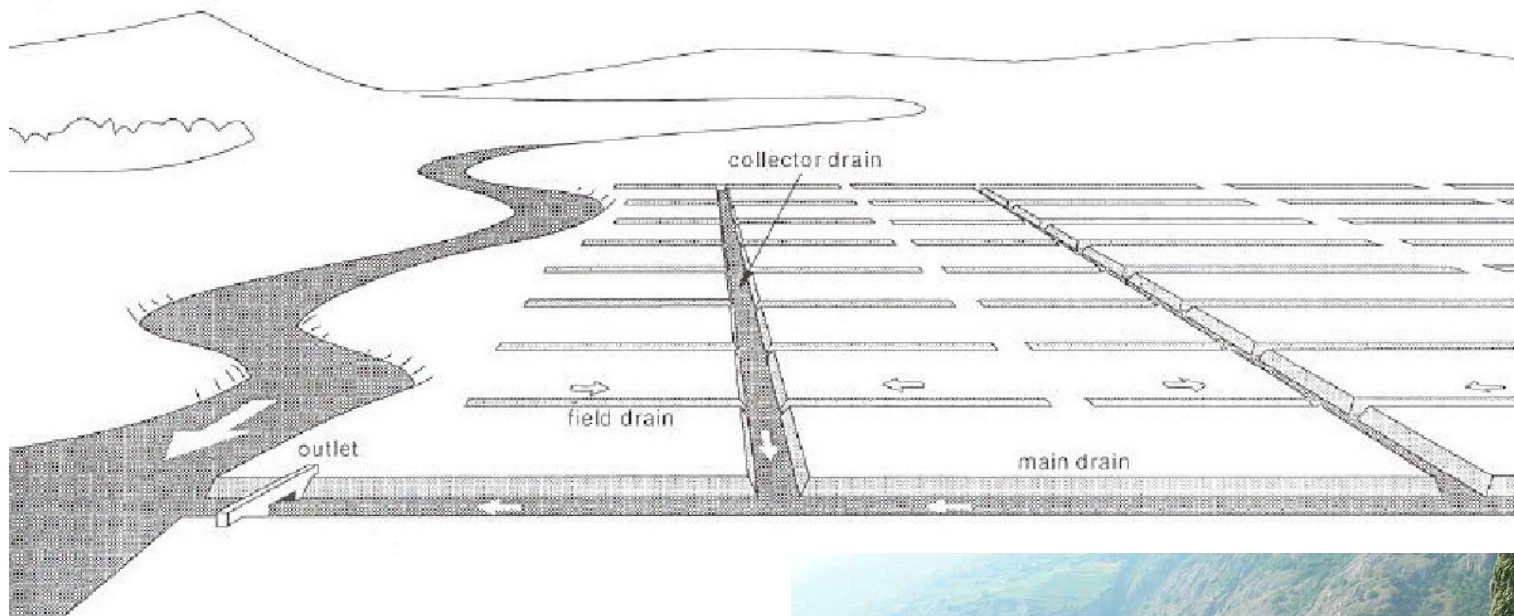

Pumping station

(where topographic differences are not sufficient to convey the water away)



Open ditch with gravity driven flow

Drainage by open ditches

Disadvantages:

- loss of arable land
- difficult to access
- expensive maintenance
- water-borne diseases



Considerable in certain cases:

- simultaneous surface and subsurface drainage
- high risk of chemical clogging
- financial reasons
- peat soils



Drainage by buried ditches

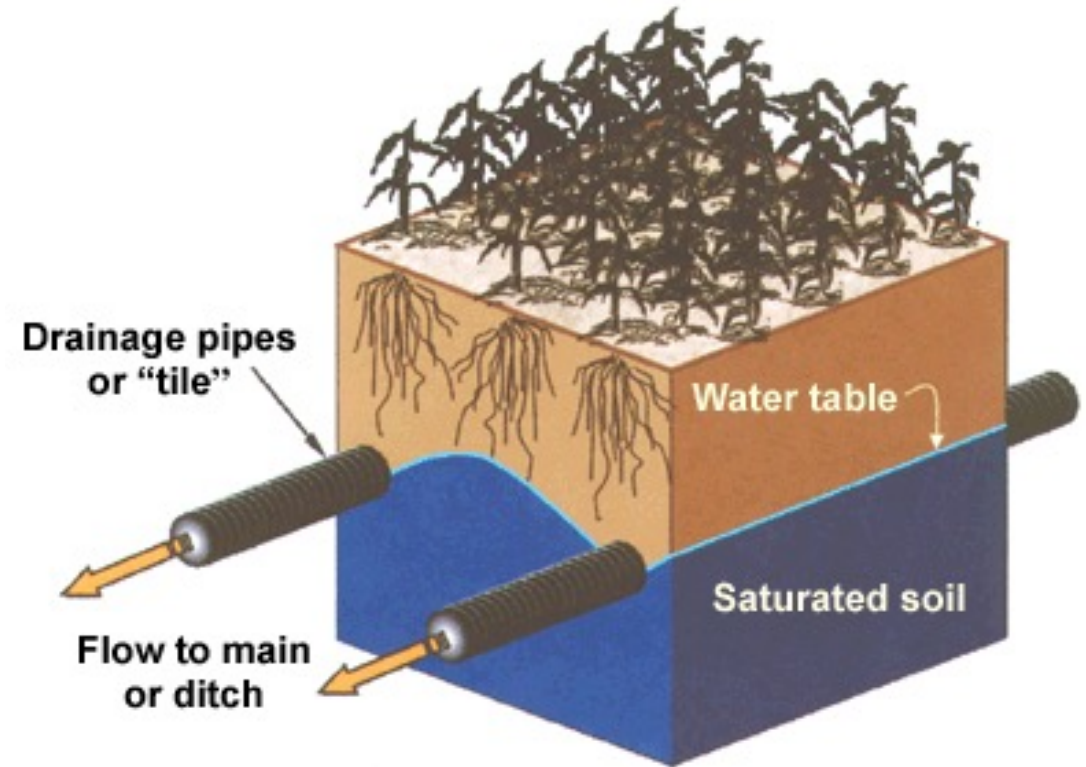
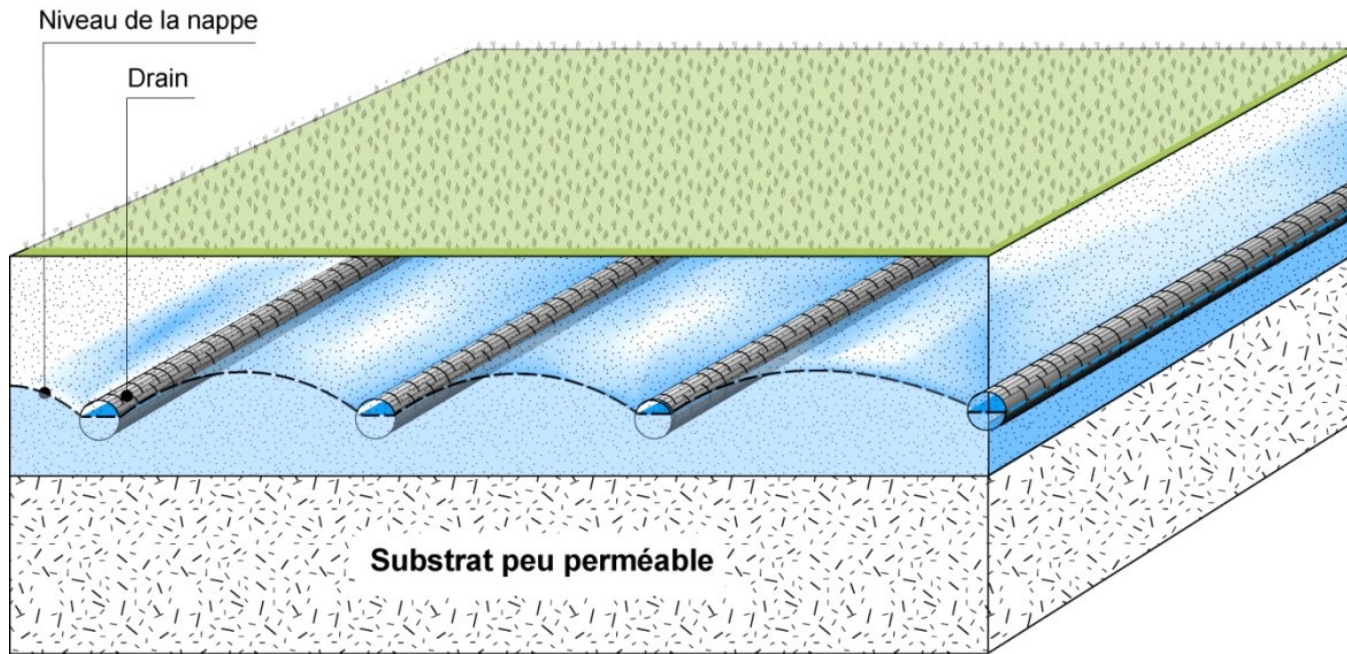

Drainage by buried ditches

- installation of drains in the ground: perforated pipes (Φ : 4 to 10 cm)
- the drains run into a network of collectors that evacuate the water to an outfall (river, lake, etc.)
- surface run-off is also often collected by means of bags (manholes covered with a grid)
- if the slope is too steep for the water to be evacuated by gravity, it is pumped up by a pumping station
- inspection chambers* are installed at key points (junctions between collectors, changes in direction and gradient, etc.).

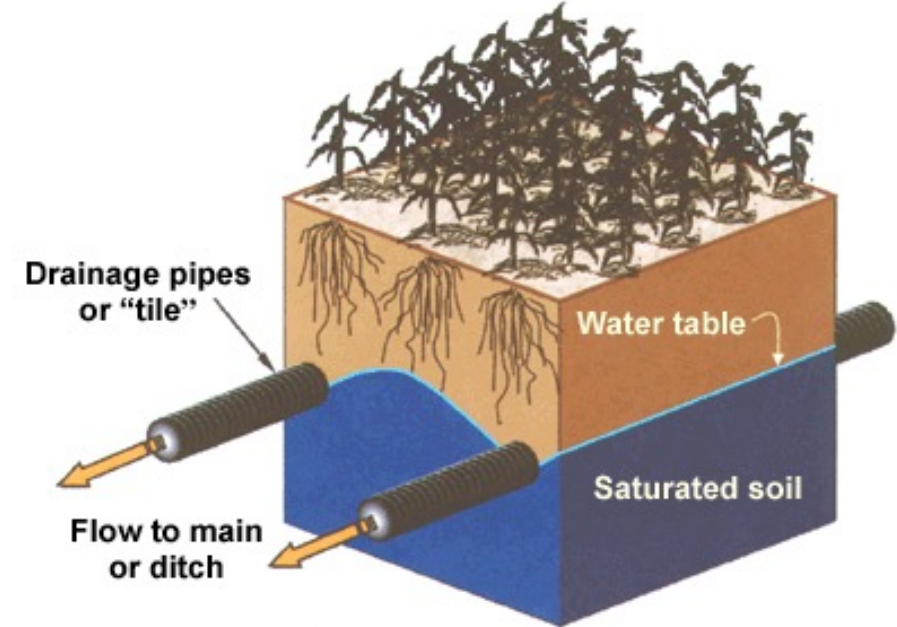

* cement manholes for checking, aerating and flushing pipes and collectors

Drainage by buried pipes

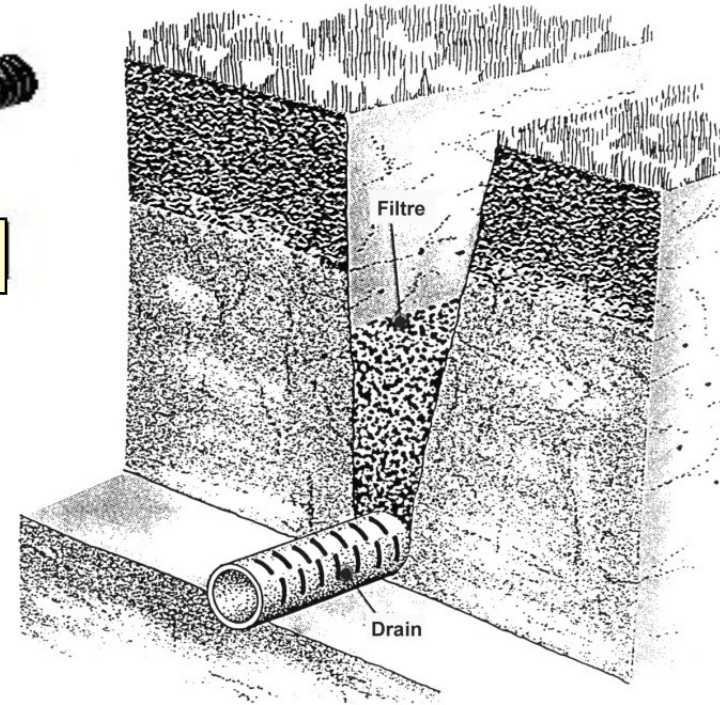
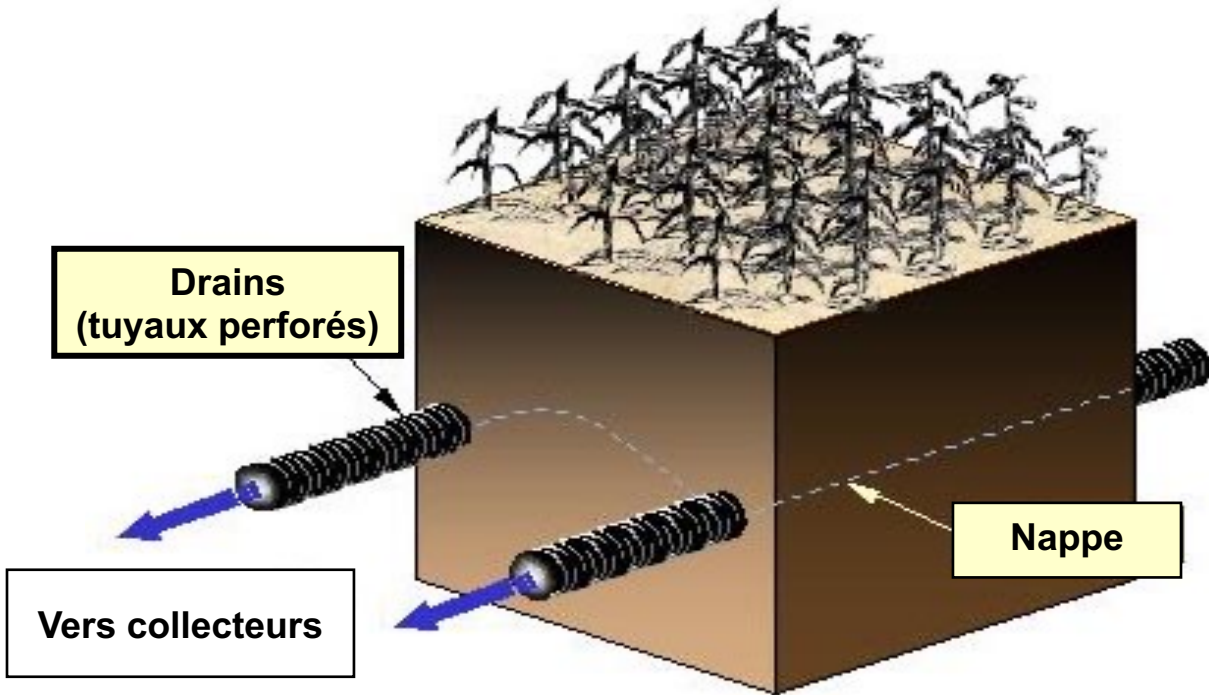

Techniques

Drainage - mole

Combines a network of conventional, wide-spaced drains (30 to 60 m and more) topped with a porous backfill, with a dense network of mole galleries*.

Practical aspects

- galleries perpendicular to the rows of drains
- diameter: approx. 4 cm
- depth: 40 to 70 cm
- spacing: 2 to 4 m
- lifespan: variable (a few years)

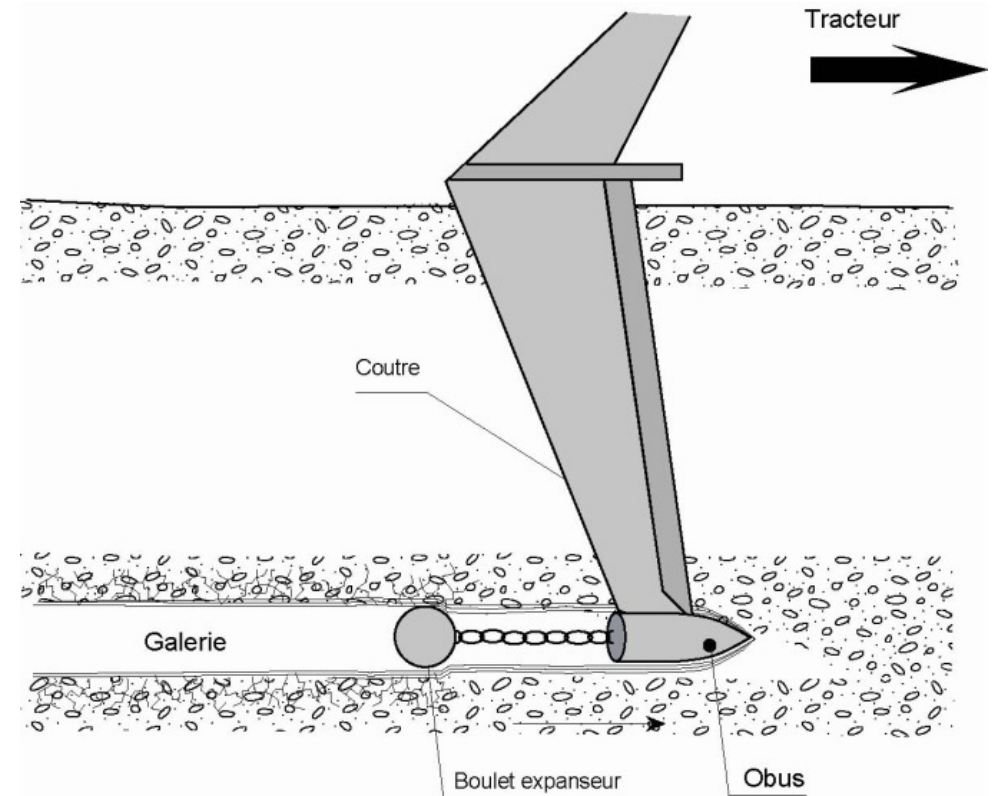

* Galleries moulded into the ground. Mole galleries are created using a mole plough fitted with an expanding ball and pulled by a tractor. The ball smoothes and compacts the walls of the gallery, which retains its shape. The soil must therefore be plastic (high clay content and sufficient moisture).

Draining galleries

Combines a conventional network of wide-spaced drains (30 to 60 m) with a dense network of perpendicular drainage galleries. Drains and galleries are topped with a gravel liner.

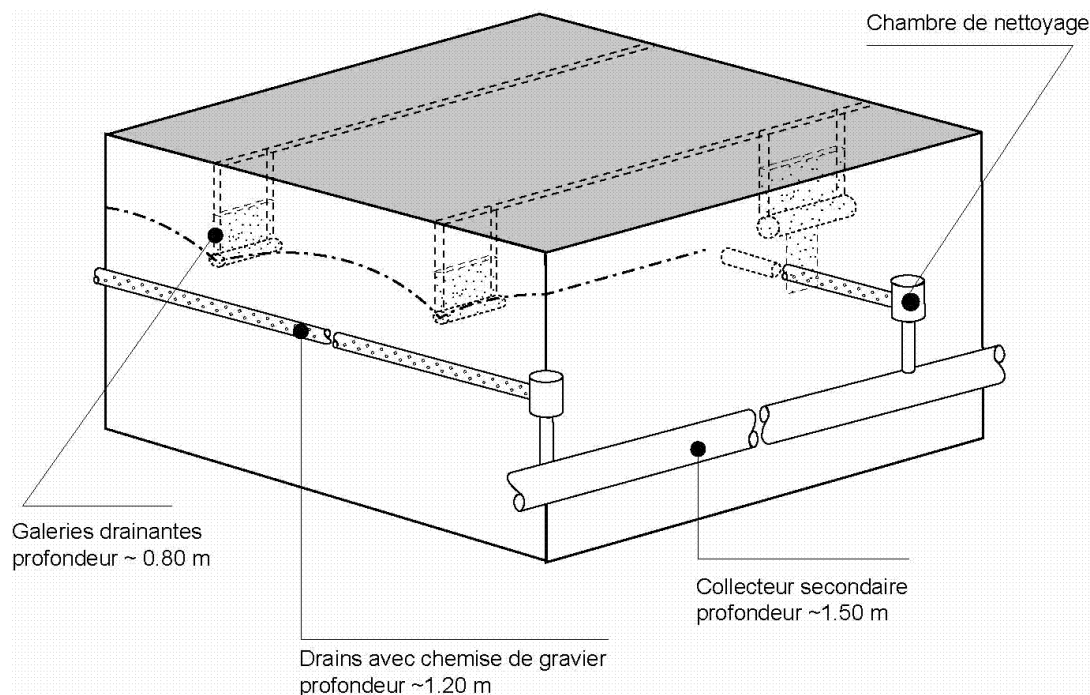

Practical aspects

- **galleries** (Φ : 10 - 12 cm) topped by a narrow liner (approx. 5 cm wide), all filled with gravel; depth: 70 to 80 cm; spacing: 10 to 15 m
- **drains**: depth: approx. 1.2 m; gradient $> 0.3\%$; drainage liner: 10 to 20 cm wide
- **Collectors**: depth: approx. 1.5 m; gradient > 0.1
- **cleaning chambers** at drain/collector junctions and inspection chambers at secondary collector/main collector junctions

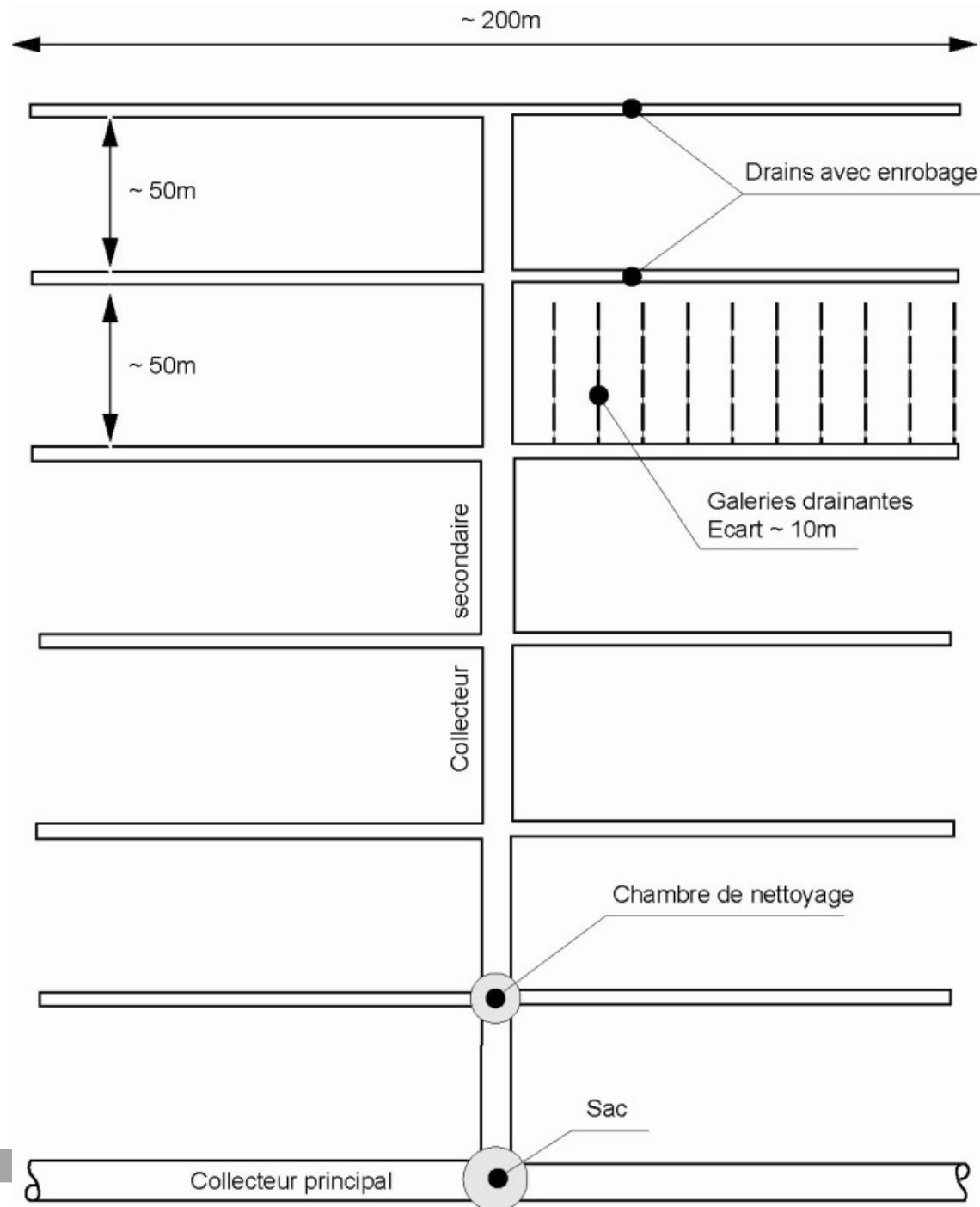

Schematic diagram of drainage using drainage galleries